

**Innovative Technology Limited** ®

## **NV7 Bank Note System**

**The Future of Smiley® Bank Note Handling**

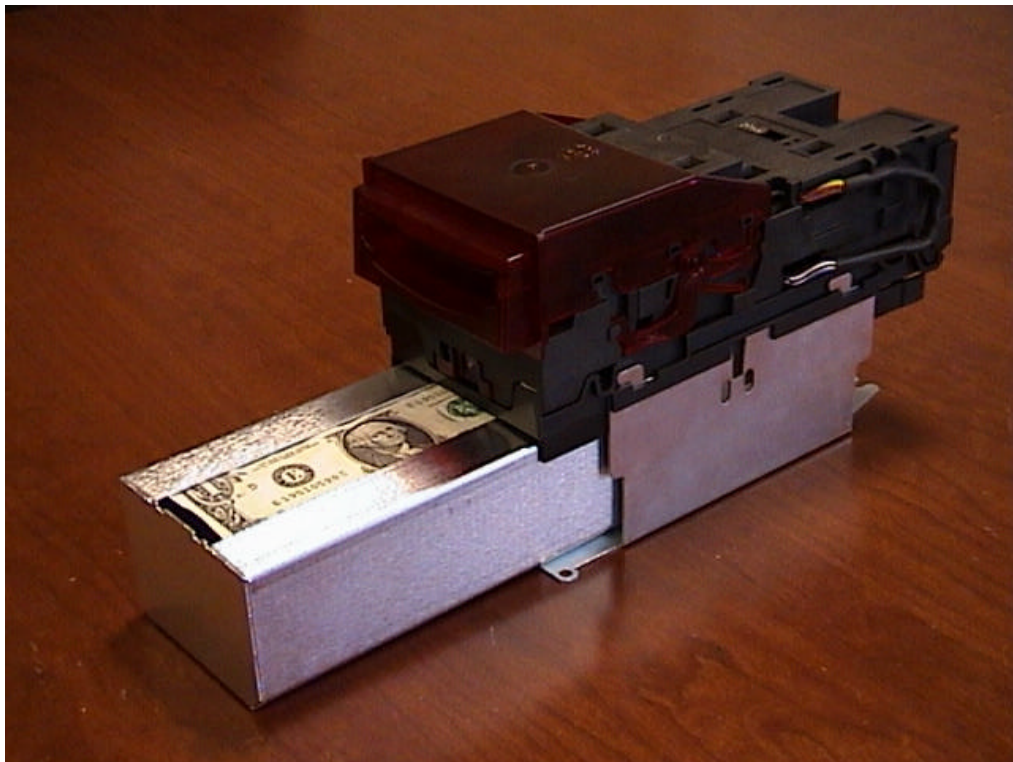

# **Operations Manual**

## **Draft A**

© Copyright Innovative Technology Limited 2001



**A.u.S. Spielgeräte GmbH A-  
1210 Wien Scheydgasse 48**

Tel. +43-1-271 66 00

Fax. +43-1-271 66 00 75

E-mail: [verkauf@aus.at](mailto:verkauf@aus.at)

<http://www.aus.at>

### ***Introduction***

This manual describes the operation of the NV7 Bank note Validator as fitted with Firmware Version 1-00

Please note that the NV7 Validator is NOT pin for pin compatible with the NV2/3/4/4X or 5 series products

We recommend that you study this manual as there are many new features permitting new uses and more secure applications.

If you do not understand any part of this manual please contact the factory for assistance. In this way we may continue to improve our product.

Smiley® and the ITL Logo are international registered trademarks and they are the property of Innovative Technology Limited.

Innovative Technology has a number of European and International Patents and Patents Pending protecting this product. If you require further details please contact:

A.u.S. Spielgeräte GmbH  
Scheydgasse 48  
A-1210 Wien  
Austria

Tel: +43 (0)1 271 66 00

Fax: +43 (0)1 271 66 00 12

Email [verkauf@aus.at](mailto:verkauf@aus.at)

Or visite our website: <http://www.aus.at>

---

## ***Scope of Document***

This document is intended for those whose will:

- a) Design the NV7 into items of equipment.
- b) Build equipment using the NV7.
- c) Install equipment containing the NV7.
- d) Maintain equipment containing the NV7.

Although information is included which will allow a degree of fault diagnosis and repair, it is recommended that for all but simple mechanical repairs the unit is returned to an approved service centre for repair.

### **CAUTION:**

Never exceed the recommended environmental and electrical limits.

Do not attempt to lubricate the mechanisms as this may affect the note transport.

Do not polish the lens as this may alter the optical characteristics.

If the NV7 Validator is disassembled the unit must be re-calibrated. In the unlikely event of a problem it is better to have the complete unit checked.

Innovative Technology Ltd has a policy of continual product improvement. As a result the products supplied may vary from the specification described here. Innovative Technology is not responsible for any loss, harm, or damage caused by the installation and use of this product. This does not affect your local statutory rights. If in doubt please contact A.u.S.Spielgeräte GmbH for details of any changes.

Alternatively visit our web site at [www.aus.at](http://www.aus.at)

---

## **General Description**

### **NV7 Validator - the next generation of Smiley® Bank Note validators**

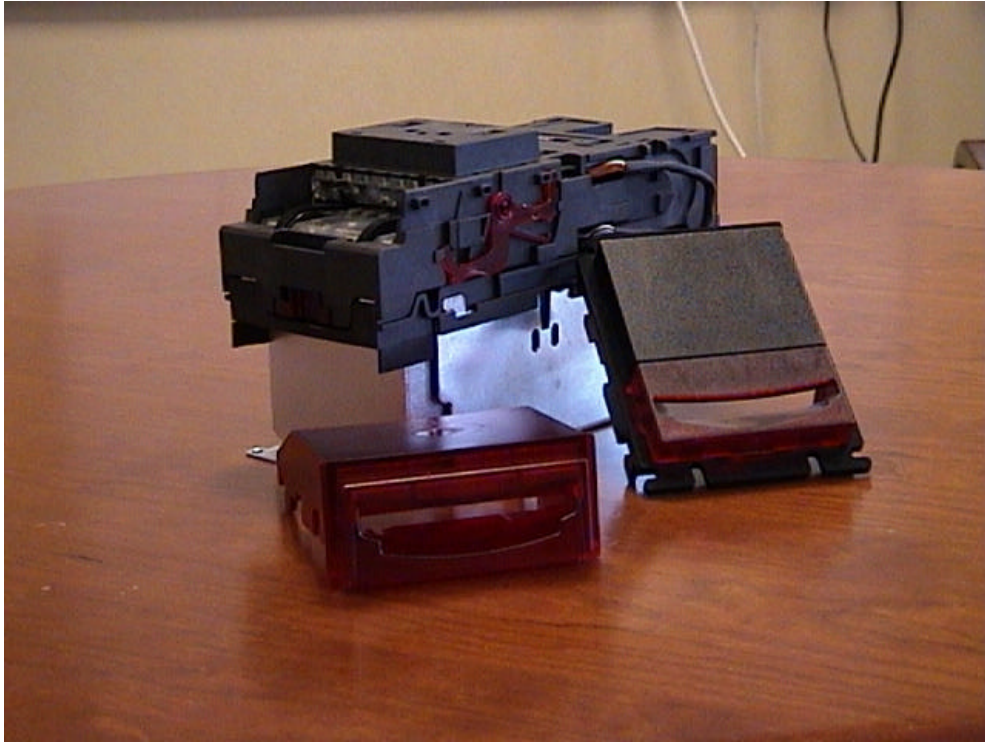

**Figure 1 – The NV7 and the vertical and universal bezels**

The NV7 Bank Note System is a compact note handling mechanism, suitable for most money machines. It will accept up to 32 different denominations of notes in the serial control mode, and will cope with different designs of banknote having the same value such as are found in the United Kingdom.

The NV7 Validator leaves the factory containing at least one currency data set so that it is ready for immediate installation. If it is desired to change the currency data set this may be done using either the NV7 to NV7 currency cloning system or the PC based Currency Management software. New currencies and applications are being tested all the time, so please refer to our web site or contact the factory for information concerning specific currencies if they are not already included on our approved list.

The NV7 has been designed for easy installation in most machines. The new stepped “smiling mouth” allows insertion of notes with one hand and simplifies the note handling mechanism.

Interfacing the Validator is very simple, with the choice of parallel open collector outputs, pulse stream output, or SSP secure serial communications.

Other communication protocols such as the MDB interface will become available in future

## NV7 Functionality. – User Display and DIP switches

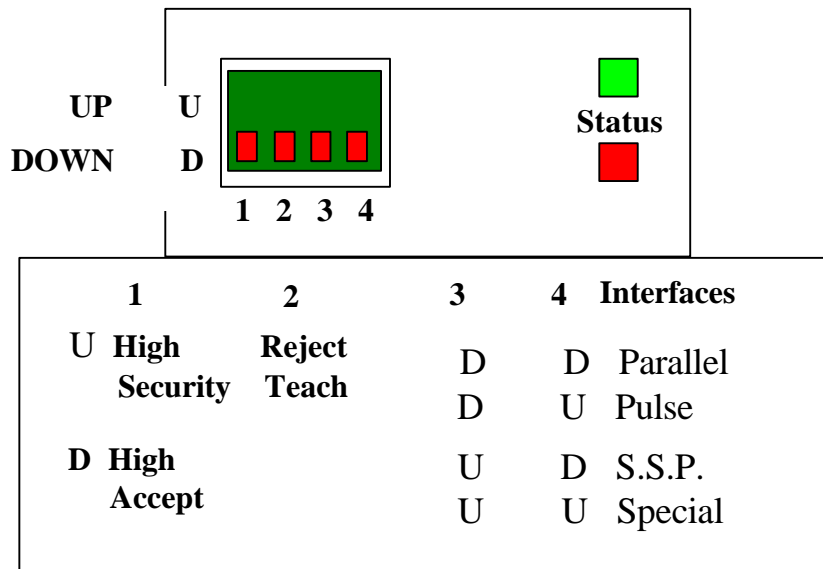

The two LED's on the top of the unit are used to provide a variety of status signals:  
The red status is used to indicate system problems – these are described below

Slow flashing green led Heartbeat (slow = 1 second period)	In normal RUN operation, when the NV7 is ready to read a note, the green status led will flash slowly ("Heartbeat") to signal a "healthy" status.
Flashing red one second period	NV7 is jammed, somewhere in the note path
Fast flashing red (fast = half second period)	NV7 cannot calibrate, sensor(s) may be blocked
Alternately flashing green then red	Stacker is full

### Switch 1: High Acceptance / High Security:

Switch 1 allows the operator to alter the security sensitivity of the NV7.

### Switch 2: Reject Teach:

If dip switch 2 is set to the UP position, notes that are to be rejected may be taught into the NV7 memory. This is for use in an emergency to reject problem notes.

To teach the problem note, insert the note at least 5 times. Then set switch 2 to the down position

## Environment and Power Requirements

Environment	Minimum	Maximum
Temperature	+3°C	+50°C
Humidity	5%	95% Non condensing

Electrical Supply	Minimum	Maximum	
Supply Voltage (V dc) Absolute Limits	11V	15V	
*MDB Versions Supply Voltage	18V	42V	
<b>NOTE: If input voltage falls below 10.5v the NV7 will reject notes</b>			
Supply Ripple Voltage	0	0.25V @100Hz	
Supply Currents			
Standby		350mA	
Validating		1000mA	
Peak (Stacker Motor stall)		1200mA	

## Interfaces: Hardware Description

Interface Logic levels	Logic Low	Logic High
Inputs	$0V < \text{Low} < 0.5$	$+3.7V < \text{High} < 12V$
Outputs with $10K\Omega$ pull up	$0.6V$	pull up voltage of host interface
Maximum Current Sink	$50mA$ per output	

Note that the output low signal is affected by the value of the pull up resistor on the host interface.

All outputs are open collector transistors.

All Inputs are held high to internal +5v via  $10K\Omega$ . The input structure is a CMOS gate with anti static protection fitted. Please ensure your signal LOW levels comply with the 74HC CMOS series specification for reliable operation.

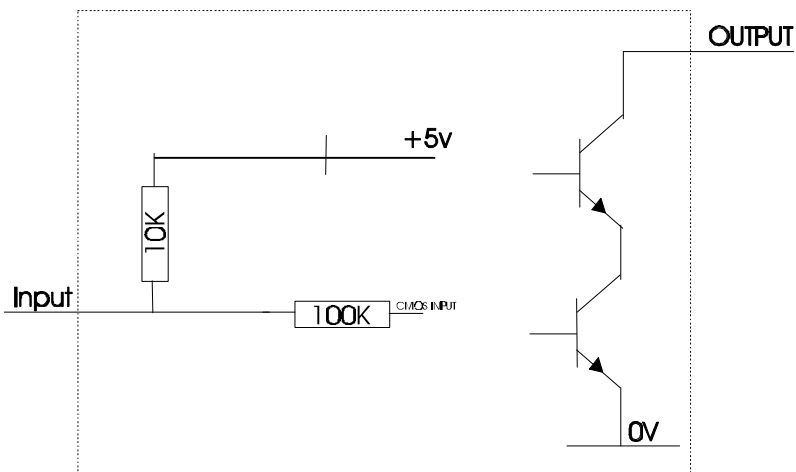

**16 Pin Connector Details:** 16 Pins, 0.1" pitch header, 2 rows by 8 pins

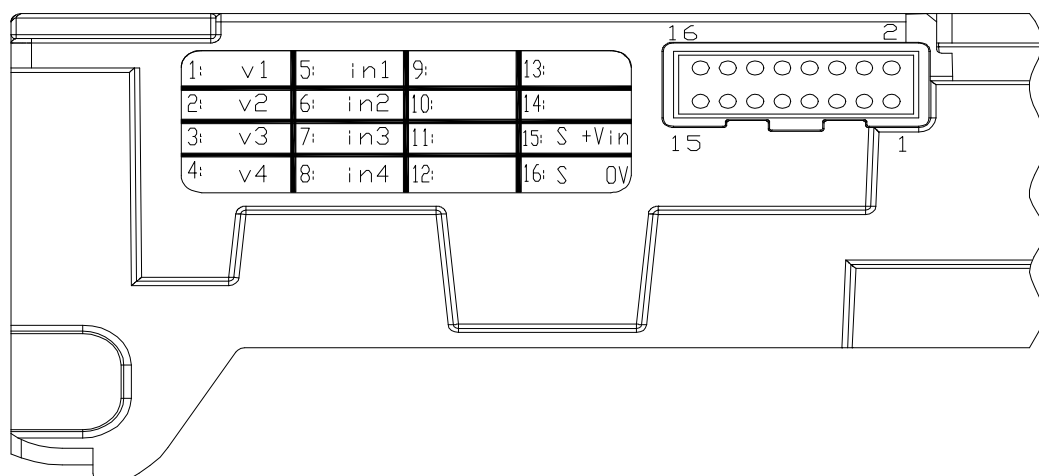

Pin	Name:	Description:
1	Vend 1	Note accepted on Channel 1, Also the Pulse Stream output Also the serial output pin in SSP Serial Mode
2	Vend 2	Note accepted on Channel 2 pulse output Also MEI HI2 Data Line, connect to Inhibit2
3	Vend 3	Note accepted on Channel 3 pulse output Also MEI HI2 Busy Line, connect to Inhibit3
4	Vend 4	Note accepted on Channel 4 pulse output
5	Inhibit 1	Inhibit channel 1 by holding this pin HIGH. To Enable a channel the inhibit must be held LOW. Also the Serial Input pin in RS232 serial mode
6	Inhibit 2	Inhibit channel 2 by holding this pin HIGH
7	Inhibit 3	Inhibit channel 3 by holding this pin HIGH
8	Inhibit 4	Inhibit channel 4 by holding this pin HIGH
9	Busy	NV7 is validating and stacking output. Active low while the NV7 is reading, transporting or stacking a note.
10	Not Used	
		<b>NOTE:</b> pins 11 to 14 have no function unless MDB software is downloaded
11	MDB TX	Optically Isolated MDB transmit output
12	MDB TX GND	Optically Isolated MDB transmit output ground
13	MDB RX GND	Optically Isolated MDB transmit input ground
14	MDB RX	Optically Isolated MDB transmit input
15	+Vin	Nominal 12V DC supply
16	0V	0v Supply

### Software Optional Serial Interface Input and Outputs

Note: these interfaces will only work if the relevant interface software is downloaded

Name:	Description:
SSP TxD	Vend 1
SSP RxD	Inhibit 1
ID003 TxD	Vend 1
ID003 RxD	Inhibit 1
HI2 Busy	Vend 3 + Inhibit 3
HI2 Data	Vend 2 + Inhibit 2



## Interfaces: Protocols

To select the required interface, the dip switches on the front/top of the NV7 must be set accordingly:-

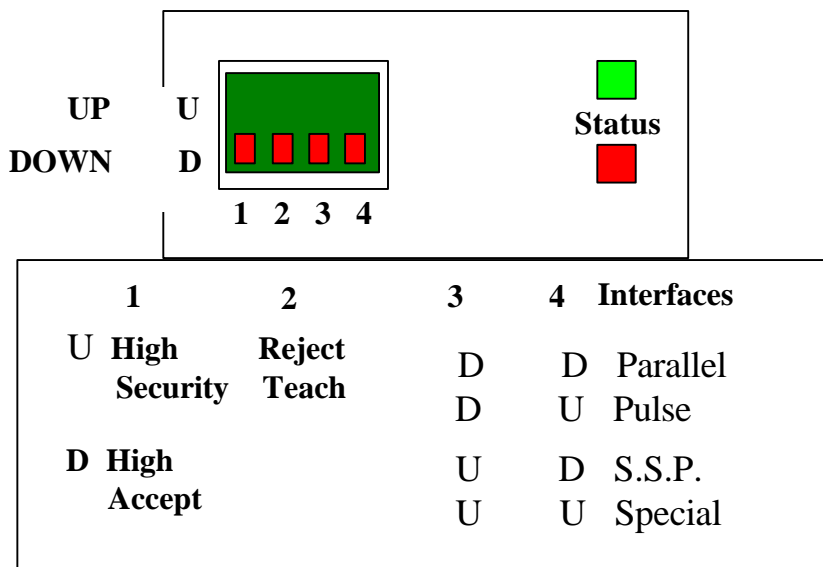

### 1: parallel input and output:

To use parallel outputs dip switch 3 and 4 must be down

**Vend Signals** (Pins 1 to 4). The four channels have their own individual outputs. If a note is recognised then the relevant channel line is pulled low for  $100 \pm 3$  milliseconds. It is recommended that pulses outside these limits are rejected as a precaution against false triggering due to noise.

**Busy Output:** (Pin 9). This is a general purpose busy signal. It is active low while the NV7 is in operation.

**Escrow Control:** escrow is only possible using the SSP serial Interface. Please refer to SSP Specification GA138-7 available on the website [www.innovative-technology.co.uk](http://www.innovative-technology.co.uk).

### Inhibit Operation

Each channel (1 to 4) has its own inhibit input to allow the host machine to refuse specified values of notes. To inhibit a channel, the relevant inhibit input must be held high. To enable a channel the corresponding inhibit must be latched low so that notes may be accepted.

If all four inhibits are high simultaneously then the NV7 will not read in any notes. In this mode, if a note is inserted the motor will run in reverse preventing the insertion of a note. All four inhibits may be connected together to create a 'global' inhibit. In this way the NV7 may be brought in and out of operation by the host machine.

It is also possible to inhibit channels using the SSP interface

### 2: Pulse Stream Output:

To use pulse stream output dip switch 3 must be down, switch 4 must be up.

When a note is recognised vend 1 will pulse a pre set number times, the number of pulses and the timing is set in the NV7 currency manager programme.

### 3: SSP Smiley Secure Protocol

Please refer to SSP Specification ITL Drawing GA 138-7 on the web site.

To help in the software implementation of the SSP protocol, Innovative Technology can provide, C Code, DLL controls and Visual Basic applications on request. Please contact the factory for assistance.

---

## Programming

Validators are normally supplied ready taught from the factory. This section may be skipped unless the validators need to be re-taught with a new note or currency.

The NV7 Validator may be taught new currency or notes in two ways:

1. Use the NV7 Currency Manager Software, which is supplied with a range of currencies. To use this system you will require a PC running Windows 95/98/NT™, Pentium™ 100MHz or faster with a serial port, and a 12volt dc power supply to power the validator. (© Microsoft and Intel). A list of currently supported currencies is maintained on our web site, and new releases can be downloaded from there. Further details are available from Sales at Innovative Technology Ltd.
2. NV7 Master/Slave copying - a currency set can be transmitted from one NV7 to another NV7

### NV7 - NV7 Copy (Cloning)

#### Overview

The facility exists for using an NV7 Bank Note Validator to copy its programme and settings to another NV7. The 'Master' validator will transmit the currency data and upgrade the slave's firmware if necessary.

#### Requirements

Master to have firmware 1-01 or greater

NV7 copy cable assembly.

12V supply.

#### NV7 Copy Cable Diagram

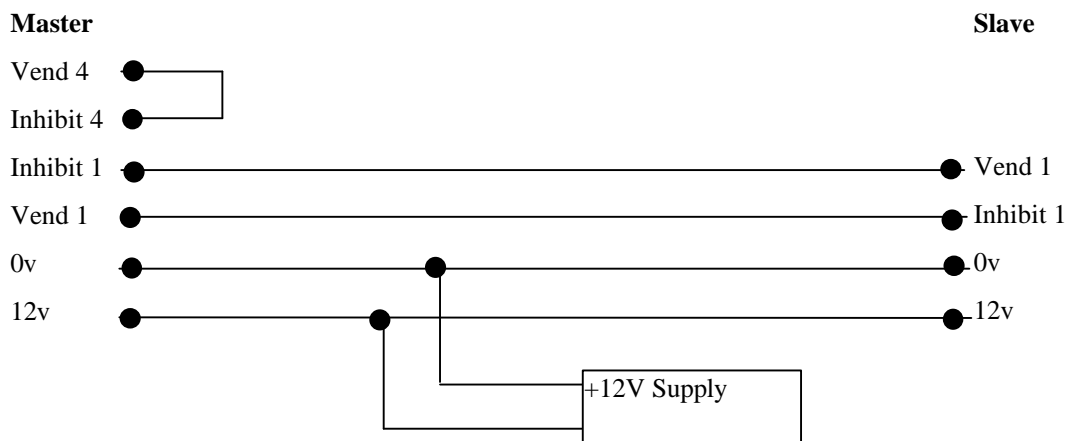

#### Start-up configuration

Remove power from slave and master units.

Set dip switches 3 UP and 4 DOWN to select SSP interface mode on both NV7s.

Connect the two units together as above. *Make sure Vend 4 is connected to Inhibit 4 on the master unit.*

*Turn on the 12V supply.*

The green led on both units will flash fast (half second period). When cloning is complete the green led on both units will flash at the normal heart beat speed (1 second period). If cloning fails to take place the master unit will flash the red light fast.

---

## ***Mechanical Installation***

The NV7 validator can be supplied with either the Horizontal Bezel (PM314 & PM315) or the Vertical bezel (PM306 & PM305).

### **Changing or removing the bezels:**

Push both of the locking arms so that they disengage from the bezel sides. The bezel may then be unhooked from the 6 locating points. To refit push the bezel onto the six locating points. The locking arms will spring back to secure the bezel.

Please make sure **both** locking arms have located correctly.

## ***Calibration and Routine Maintenance***

The NV7 Validator has been designed to minimise any performance variation over time. Much of this is achieved by careful hardware and software design. However, depending upon the environment the NV7 may at some time require cleaning or even re-calibration.

### **Cleaning:**

Slide the red catch on the end of the NV7 Validator to open the note path. The note path and lozenge may now be exposed for cleaning. Wipe the surfaces with a soft lint free cloth that has been dampened with a water and detergent solution (such as a household washing up liquid) **NEVER** use a solvent based cleaner such as alcohol, petrol, methylated spirits, white spirit, or PCB cleaner. This will result in permanent damage to the validator. Take particular care around the lenses. If a lens has become badly scratched do not attempt to polish it as this may damage the optical properties.

### **Re-Calibration:**

The NV7 has an in-built self calibration system that maintains the optical sensors at their best operating point. However if the NV7 is disassembled for any reason it will need to be re-calibrated. This is best done in conjunction with the diagnostics software.- follow the help menus supplied with this programme.

## ***Fault Finding***

Problem	Check:	Solution
Validator will not take notes:	Is the Bezel Illuminated?	Check power supply, Check interface system
	Is the jumper cable connected from the top to the bottom of the validator?	Test cable
Validator runs slowly or intermittently:	Make sure there are no foreign objects in the note path	Clean the note path
	Check voltage level of supply	Ensure correct supply and sufficient current.
	Check for damage	Replace Path components
	Ensure there is no grease on drive belts	Replace belts
Notes pass through the validator but do not give a vend signal	Is the power supply inside specification. Which interface have you selected	Ensure correct supply and sufficient current. Check dip switch settings Check Interface system
Unit rejects genuine notes	Check that the unit has been programmed for this note.	Check Currency on label
	Check the security setting	Adjust security setting
Notes not stacking correctly	Is cash box fitted? Is cash box damaged Incorrect cash box for NV7	Replace cash box

---

## **Support Tools**

The following support tools are available for use with the NV7 Bank Note Validator:

1. PC Currency Manager Software.
2. PC Hardware Diagnostics Software.
3. Downloads from the Innovative Technology Ltd website: **[www.innovative-technology.co.uk](http://www.innovative-technology.co.uk)**

### **1. PC Currency Programming Software.**

The NV7 Currency Manager software offers the following functions:

- teach the NV7 Validator by downloading pre-prepared currency data via the serial communications link. The firmware will also be updated to the version compatible with the currency set to ensure maximum security.
- Check the firmware version and currency set already loaded on an NV7 unit
- Adjust the channel and pulse configuration on a pre-programmed NV7 to your own requirements
- download a new version of firmware onto the NV7
- upload the currency data in an NV7 and save to file

The software will run on an IBM compatible Personal Computer with Pentium™ processor or equivalent and requires a DA1 which must be fitted to the PC serial port. This program runs under the Windows 95/98/NT™ operating system, and requires one free serial port to connect to the NV7. (© Microsoft and Intel).

### **2. PC Hardware Diagnostics Software.**

In order to assist with the repair and testing of NV7, a diagnostic software package is available which allows the various functions of the validator to be individually operated remotely from a PC using a serial link.

The software will run on an IBM compatible Personal Computer with Pentium™ processor or equivalent. This program runs under the Windows 95/98/NT™ operating system, and requires one free serial port to connect to the NV7 using the DA1 kit (© Microsoft and Intel)

### **3. Internet Website support.**

The Innovative Technology Ltd website provides the means to download new and updated currency sets and new versions of firmware for the NV7. Visit [www.aus.at](http://www.aus.at) for further details. Technical bulletins are also made available. Note the files are password protected to prevent abuse. Periodically the passwords are changed. Please contact sales at A.u.S.Spielgeräte GmbH for password updates.

### **4. Email Support.**

If the data you require is not available over the internet Innovative Technology supports an email system to help customers with unusual requirements. The address is [verkauf@aus.at](mailto:verkauf@aus.at) or [technik@aus.at](mailto:technik@aus.at)



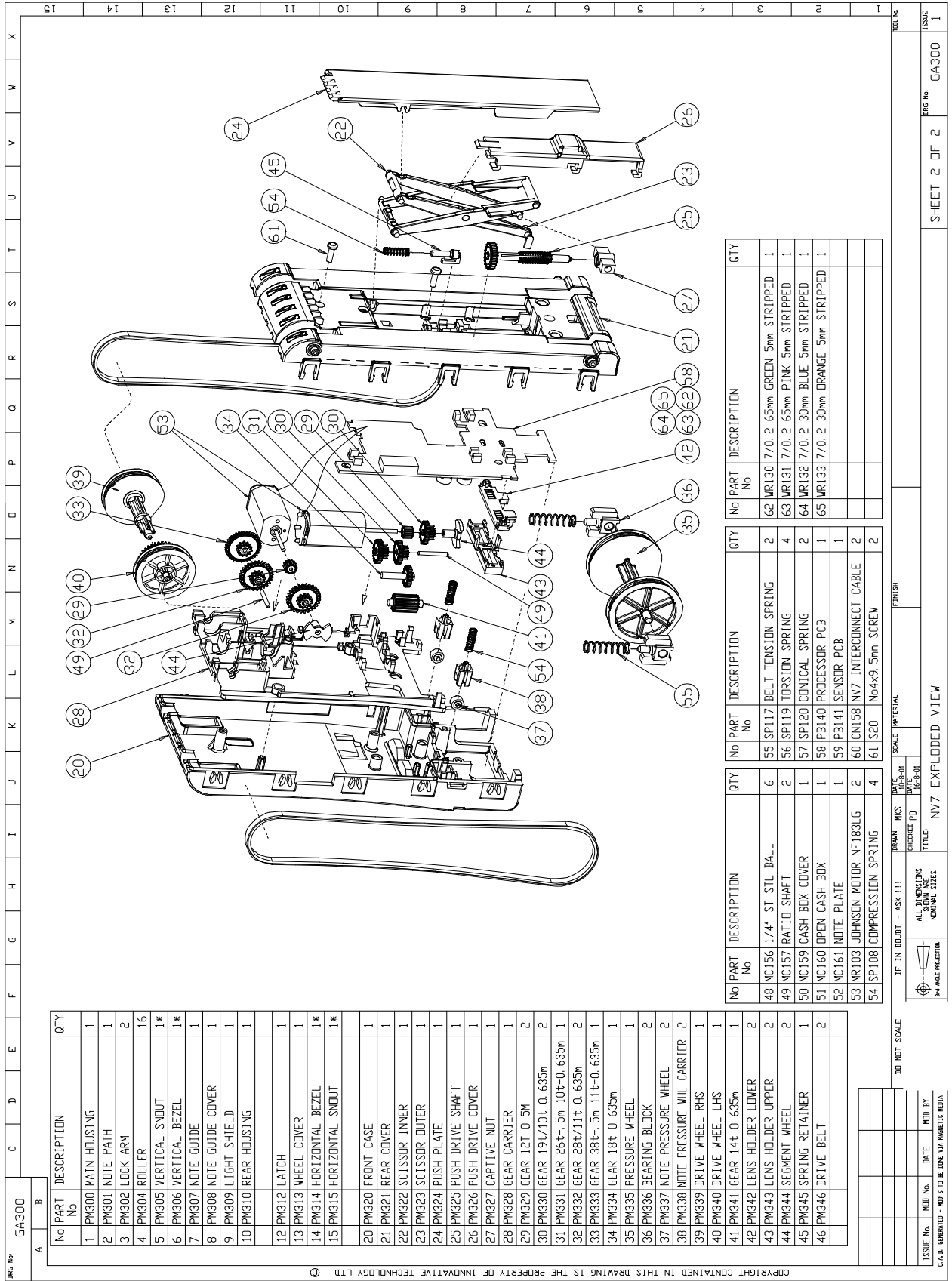

No	PART DESCRIPTION	QTY
1	PK300 MAIN HOUSING	1
2	PK301 NOTE PATH	1
3	PK302 LOCK ARM	2
4	PK304 ROLLER	16
5	PK305 VERTICAL SNOUT	1*
6	PK306 VERTICAL BEZEL	1*
7	PK307 NOTE GUIDE	1
8	PK308 NOTE GUIDE COVER	1
9	PK309 LIGHT SHIELD	1
10	PK310 REAR HOUSING	1
12	PK312 LATCH	1
13	PK313 WHEEL COVER	1
14	PK314 HORIZONTAL BEZEL	1*
15	PK315 HORIZONTAL SNOUT	1*
20	PK320 FRONT CASE	1
21	PK321 REAR COVER	1
22	PK322 SCISSOR INNER	1
23	PK323 SCISSOR OUTER	1
24	PK324 PUSH PLATE	1
25	PK325 PUSH DRIVE SHAFT	1
26	PK326 PUSH DRIVE COVER	1
27	PK327 CAPTIVE NUT	1
28	PK328 GEAR CARRIER	1
29	PK329 GEAR 12T 0.5M	2
30	PK330 GEAR 19T/10T 0.635m	2
31	PK331 GEAR 26T-, 5m 10T-0.635m	1
32	PK332 GEAR 28T/11T 0.635m	2
33	PK333 GEAR 38T-, 5m 11T-0.635m	1
34	PK334 GEAR 18T 0.635m	1
35	PK335 PRESSURE WHEEL	1
36	PK336 BEARING BLOCK	2
37	PK337 NOTE PRESSURE WHEEL	2
38	PK338 NOTE PRESSURE WHL CARRIER	2
39	PK339 DRIVE WHEEL RHS	1
40	PK340 DRIVE WHEEL LHS	1
41	PK341 GEAR 14T 0.635m	1
42	PK342 LENS HOLDER LOWER	2
43	PK343 LENS HOLDER UPPER	2
44	PK344 SEGMENT WHEEL	2
45	PK345 SPRING RETAINER	1
46	PK346 DRIVE BELT	2

No	PART DESCRIPTION	QTY
55	SP117 BELT TENSION SPRING	2
56	SP119 TORSION SPRING	4
57	SP120 CONICAL SPRING	2
58	PB140 PROCESSOR PCB	1
59	PB141 SENSOR PCB	1
60	CN158 NV7 INTERCONNECT CABLE	2
61	S20 No4x9.5mm SCREW	2

IF IN DOUBT - ASK !!!  
 DRAWN: MJS  
 CHECKED: PJD  
 DATE: 16-8-01  
 ALL DIMENSIONS IN MILLIMETERS UNLESS OTHERWISE STATED  
 FINISH: NV7 EXPLODED VIEW  
 SCALE: MATERIAL:

DO NOT SCALE  
 15  
 14  
 13  
 12  
 11  
 10  
 9  
 8  
 7  
 6  
 5  
 4  
 3  
 2  
 1

GA300  
 SHEET 2 OF 2  
 BRG No. GA300  
 ISSUE 1





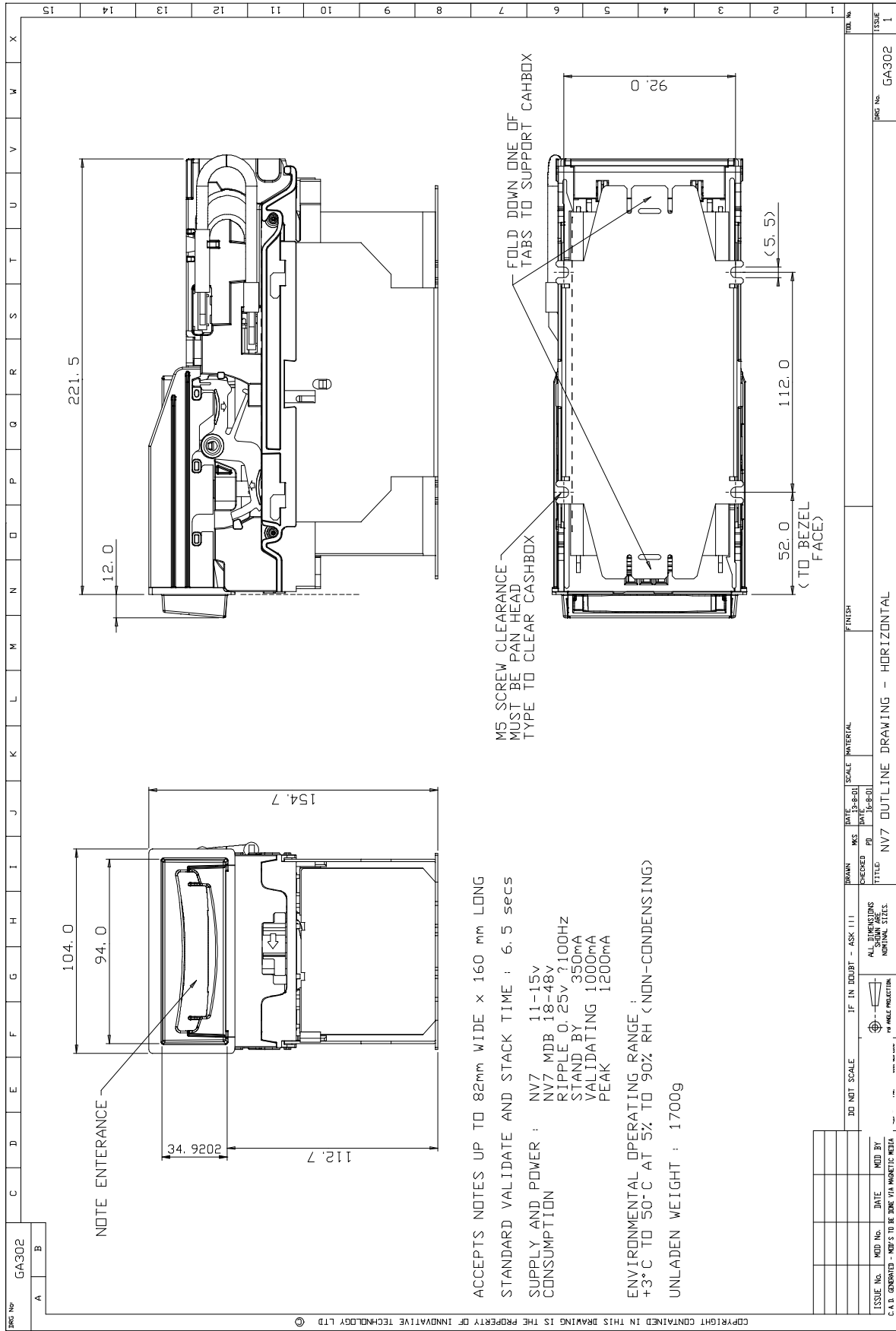

Copyright contained in this drawing is the property of Innovative Technology Ltd ©



---

### ***Revision History***

Issue No.	Mod No.	Date	Done by
Draft A	NA	July 2001	KA