

NV9 Product Spare Part Overview

1.1	NV9	2
1.2	Bezel.....	3
1.3	Cash Boxes	5
1.4	Main Parts And Components	6
1.4.1	Main Housing.....	6
1.4.2	Lozenge.....	7
1.4.3	Rear Housing	9
1.5	Layers	10
1.5.1	Electronic Components	10



A.u.S. Spielgeräte GesmbH
Scheydgasse 48 A-1210 Wien
Tel. +43-1-271 66 00 Fax. +43-1-271 66 00 75
E-mail: verkauf@aus.at
<http://www.aus.at> <http://www.garlando.at>
Öffnungszeiten: Mo-Do 9-18 und Fr. 9-17 Uhr

NV9 Product Spare Part Overview

1.1 NV9

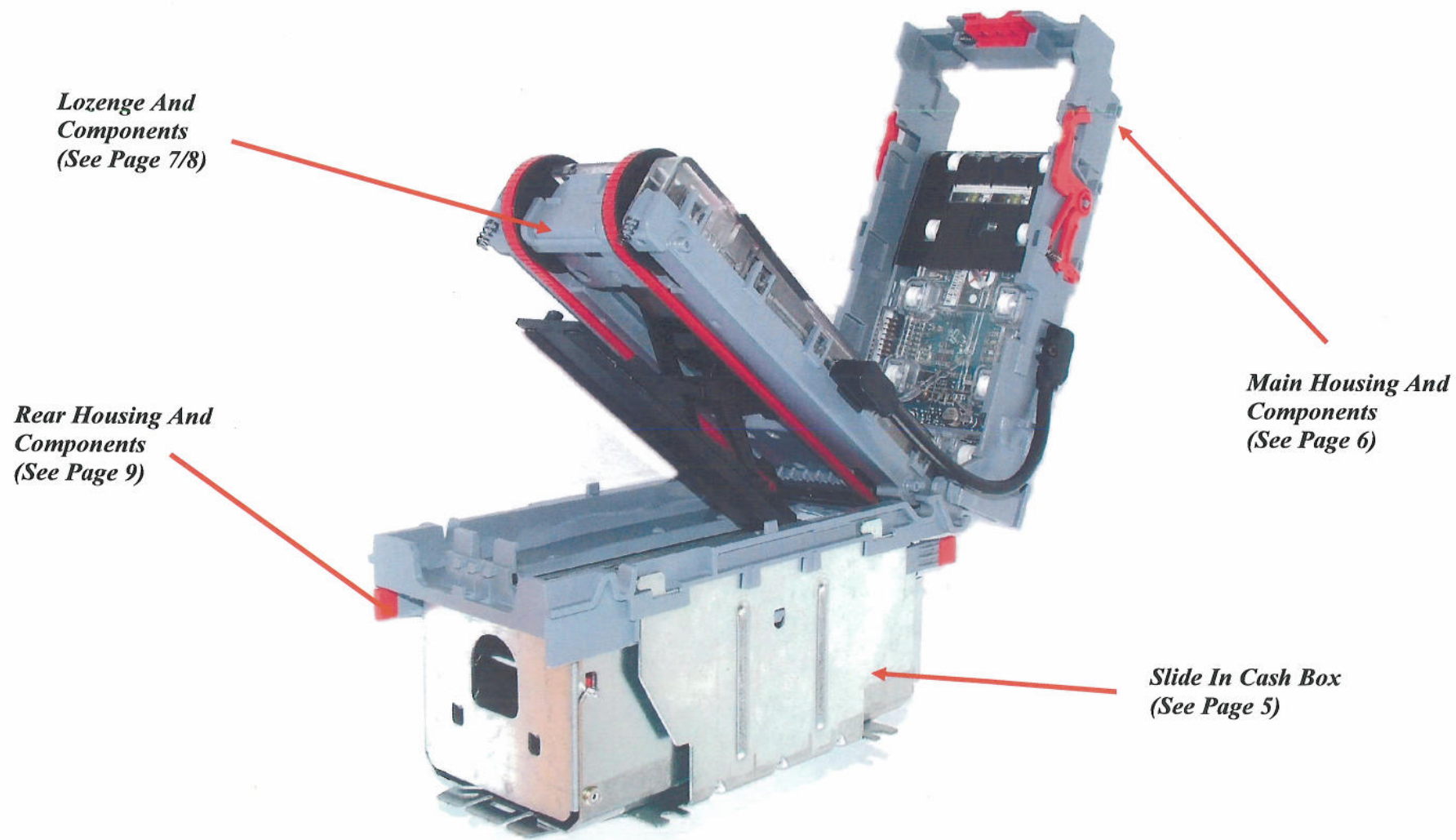

NV9 Product Spare Part Overview

1.2 Bezel



PA188
*Vertical Up Stack
Bezel Assembly*



PA188BK
*Vertical Up Stack
Bezel Assembly (black)*



PA189
Horizontal Bezel Assembly



PA189BK
Horizontal Bezel Assembly (black)



PA190
*Vertical Up Stack Extended
Snout Bezel Assembly*



PA190BK
*Vertical Up Stack Extended
Snout Bezel Assembly (black)*



PA191
*Vertical Down Stack Extended
Snout Bezel Assembly*



PA191BK
*Vertical Down Stack Extended
Snout Bezel Assembly (black)*

NV9 Product Spare Part Overview



PA256
66mm Vertical Up Bezel

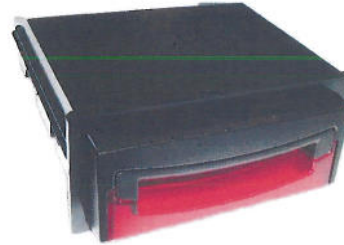

PA257
66mm Fixed Width Horizontal Bezel



PA257BK
66mm Fixed Width Horizontal Bezel (black)



PA268
69mm Fixed Width Horizontal Bezel



PA268BK
69mm Fixed Width Horizontal Bezel (black)



PA296
Vertical Up/Down Flat 66mm Bezel Assy



PA296BK
Vertical Up/Down Flat 66mm Bezel Assy (black)

NV9 Product Spare Part Overview

1.3 Cash Boxes

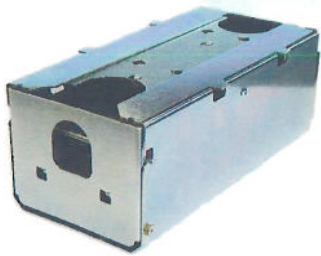

PA185
*Clip On Cash Box
Assembly (300C)*

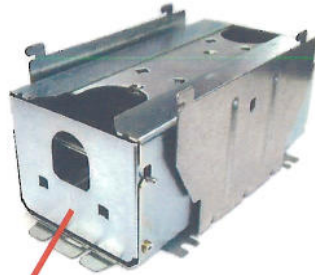

PA192
*Slide In Cash Box
Assembly (300S)*

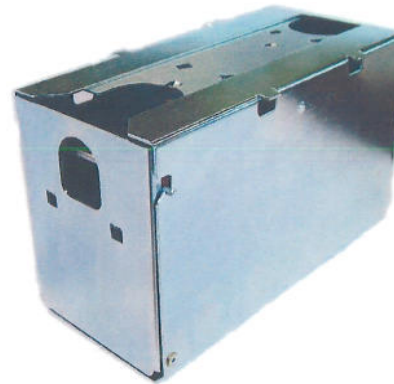

PA193
*Clip On Cash Box Assembly
(600C)*



PA194
*Slide In Cash Box Assembly
(600S)*



PA297
*Inner Cash Box 300 Notes
(For PA192 Only)*



PA326
*Inner Cash Box 600 Notes
(For PA194 Only)*

NV9 Product Spare Part Overview

1.4 Main Parts And Components

1.4.1 Main Housing

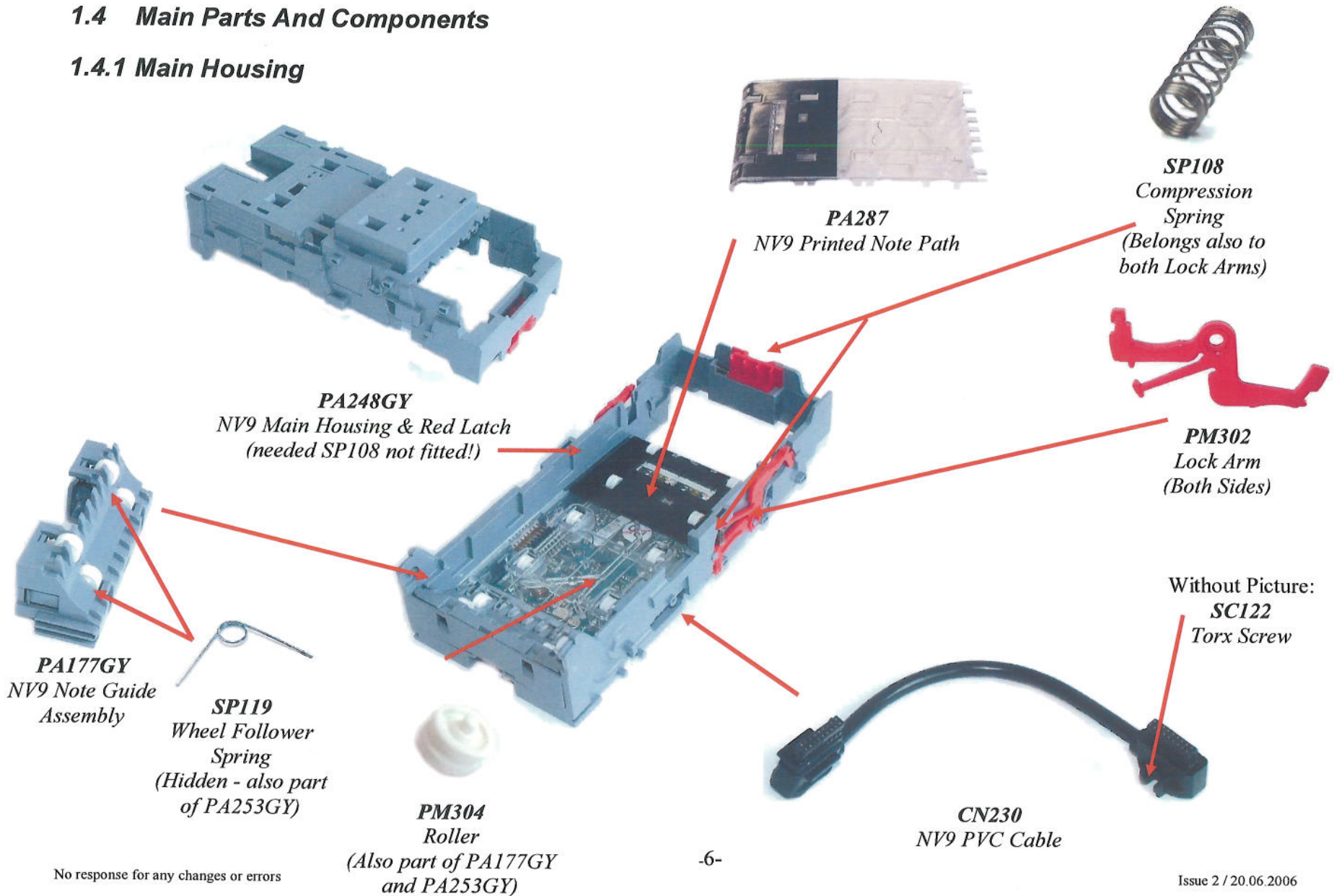

No response for any changes or errors

NV9 Product Spare Part Overview

1.4.2 Lozenge

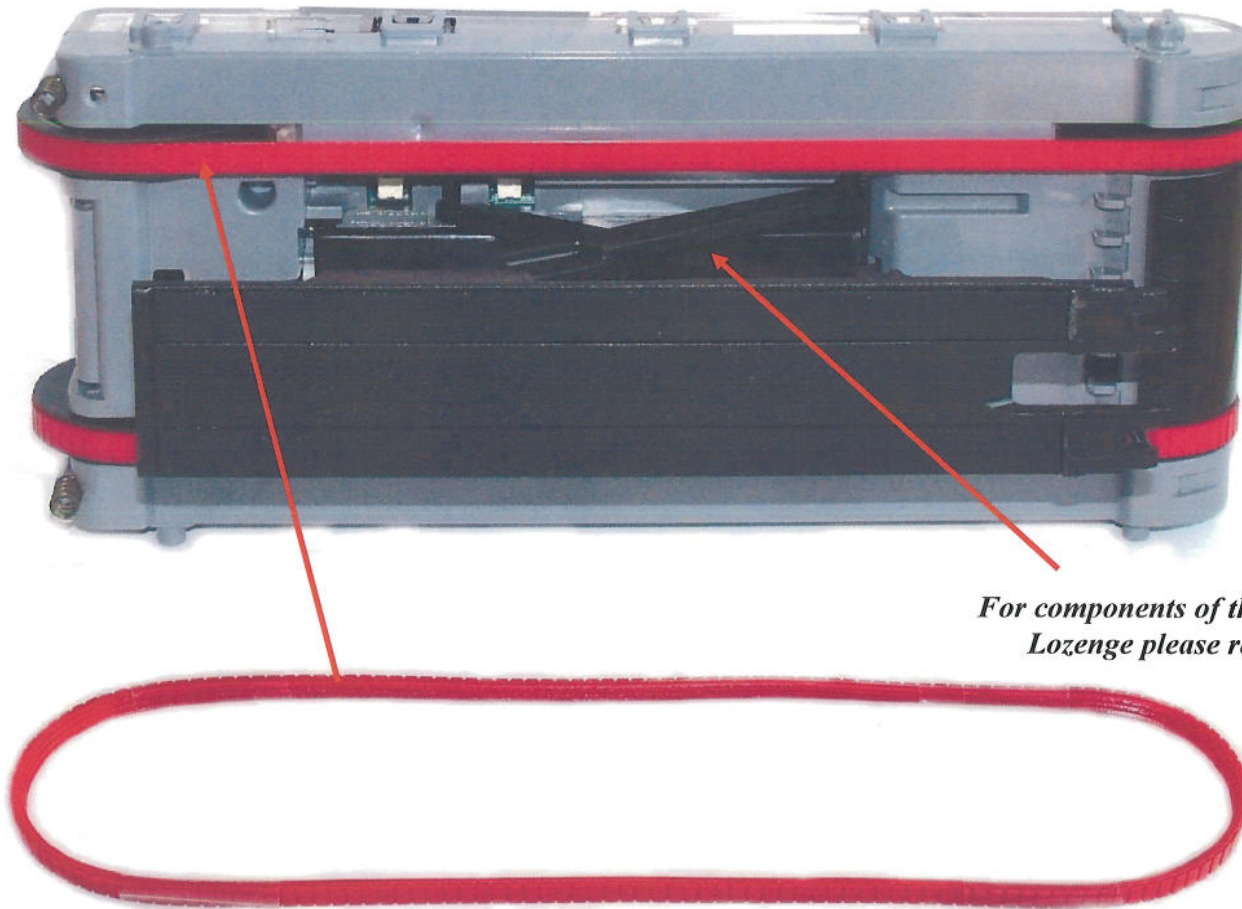

FD106
NV7/9 Red Drive Belt

NV9 Product Spare Part Overview

Lozenge (lower part)

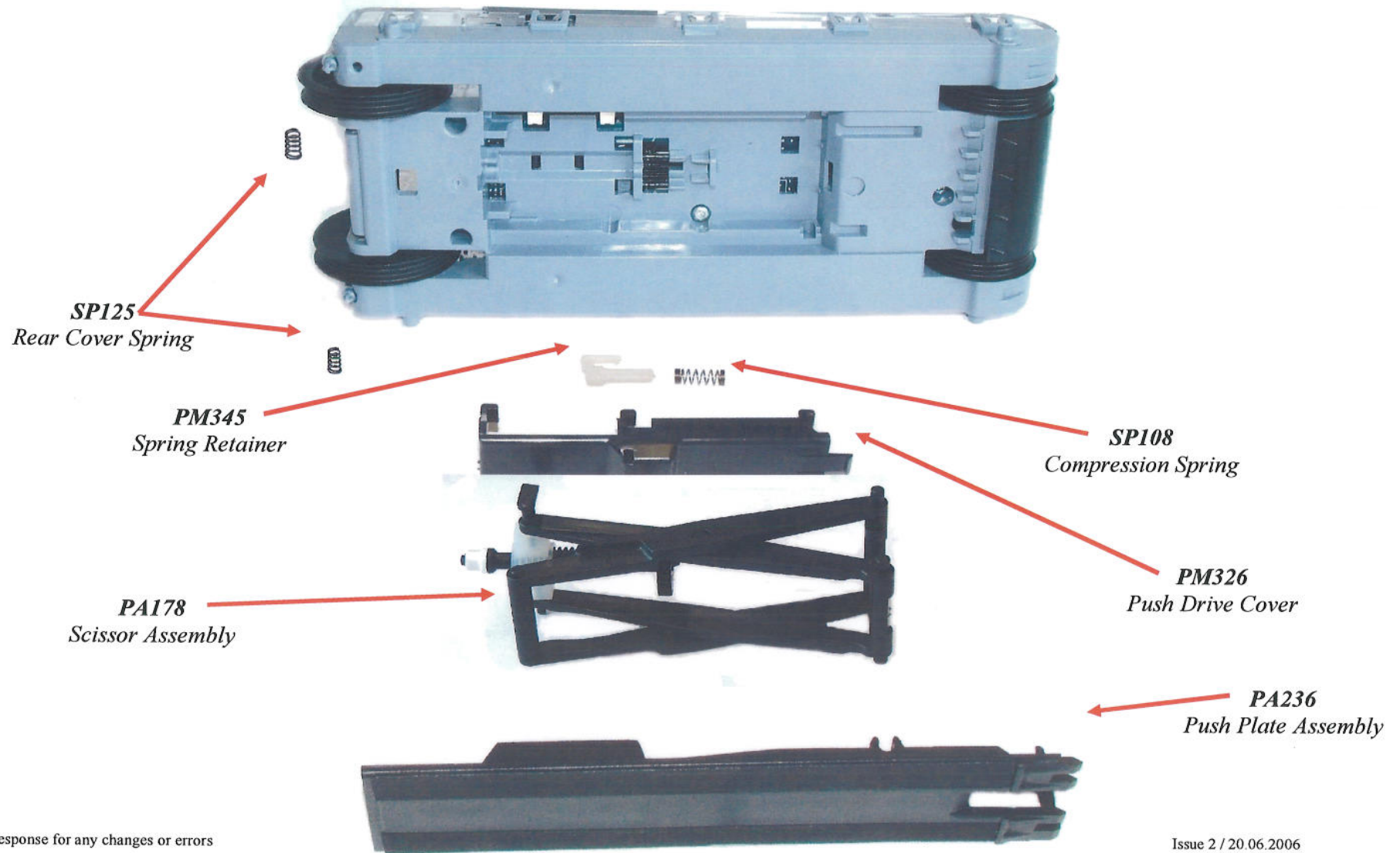

NV9 Product Spare Part Overview

1.4.3 Rear Housing

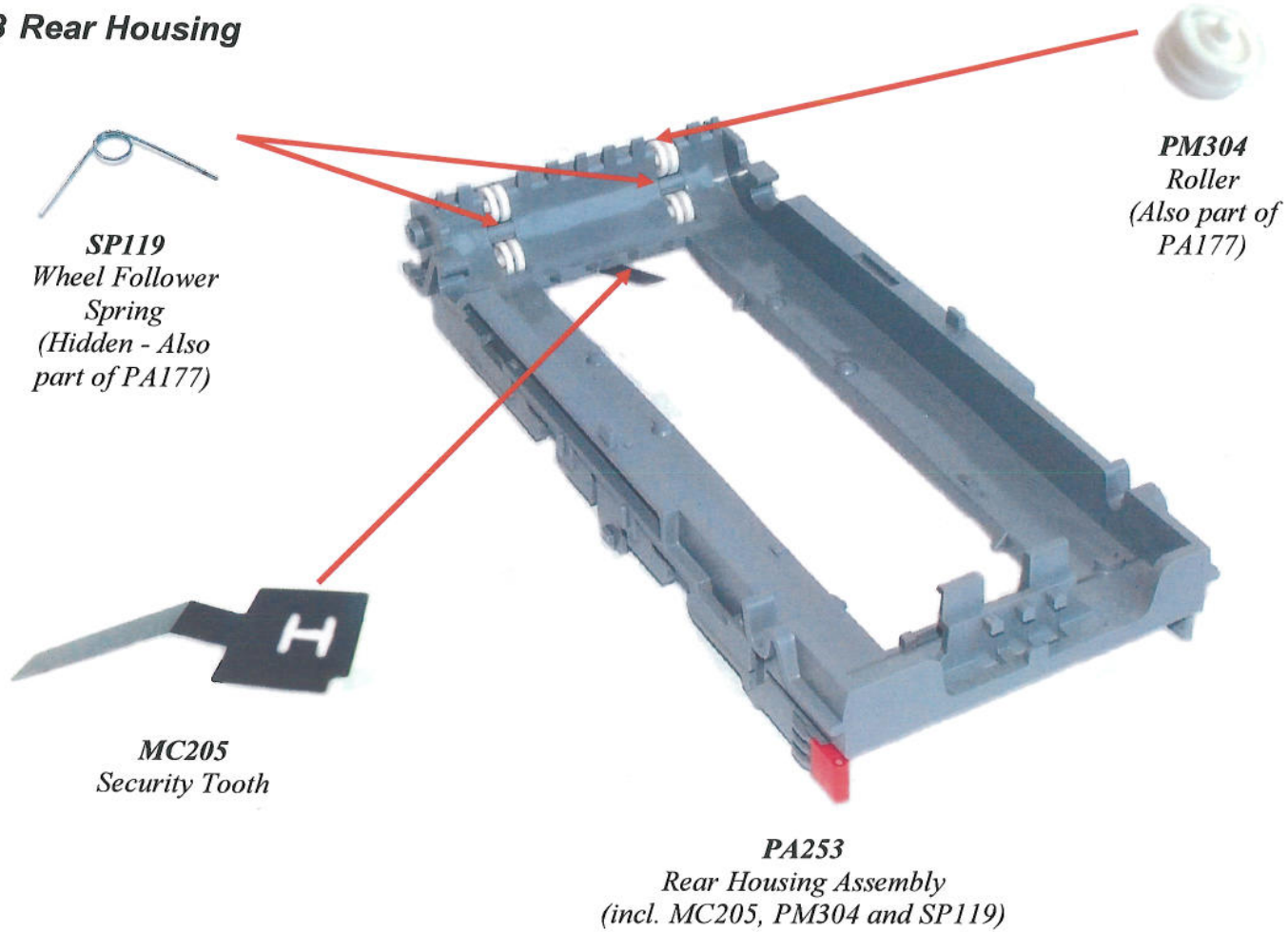

NV9 Product Spare Part Overview

1.5 Layers

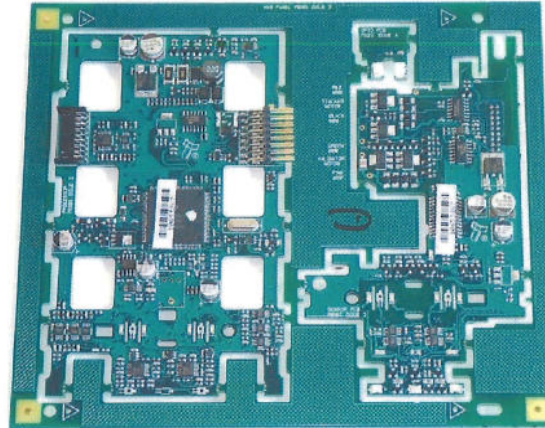

PB185_CNV
NV9 Mother Board

1.5.1 Electronic Components

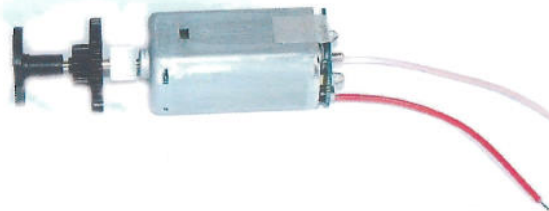

PA305
NV9 Motor Drive Assembly With Wires



PA306
NV9 Stacker Motor Assembly With Wires